

Combi steamer

Junior

Electric combi steamer Junior MagicPilot 6.23

MKN-No.: SKECOD623TG2



world of cooking

Features

- **MagicPilot** – touch and slide operating concept
robust, wear-free, capacitive true colour touch screen,
protected behind anti-reflective safety glass;
display cleaning mode
- **MKN Guided Cooking** with autoChef, ChefsHelp,
VideoAssist, Favourites and BarcodeScan
- **autoChef** – automatic cooking
- More than 250 preselected international cooking
processes which can be individually modified
- More than 350 cooking processes can be saved
- **Overview of individual favourites** on the start screen
- Cooking process protection against
modification/deletion
- Adjustable language settings, full text search
- **ChefsHelp** – user information
Insertion of information into text and graphics where
required during the cooking process
- **VideoAssist** – interactive user assistance with clips
featuring professional chefs
- Start cooking process with **BarcodeScan** in autoChef
- **Manual operation concept** with 12 cooking modes:
SoftSteaming, Steaming, ExpressSteaming, Convection,
CombiSteaming, Perfection, low temperature cooking, ΔT ,
Sous vide, humidification, baking and rest function
- Cooking Steps function – up to 20 programme steps can
be individually combined
- **SES** – Steam Exhaust System,
steam extraction for safe operation
- **GreenInside** – energy consumption display
- **CombiDoctor** – self diagnosis programme
automatic self-test for all relevant appliance functions such
as climate and cleaning functions
- **FamilyMix** – efficient utilization of the cooking chamber
capacity. Products which can be cooked in the same
cooking chamber climate are indicated in a clearly
arranged list showing which products belong together.
- **QualityControl** – consistent high quality; perfect results
every time regardless of the load quantity
- **Hygienic cooking chamber door with
sealed triple glazing**
- LED lighting integrated into the hygienic cooking chamber
door
- Right hand hinged door
- **Hygienic cooking chamber** of corrosion resistant
stainless steel

Accessories

- Hanging rack for lengthwise insertion, standard configu-
ration, 6 shelf inserts for GN 2/3, with tilt protection for
containers, distance between insert levels 60 mm
- Mains connection cable as standard



Option

- **WaveClean** – automatic cleaning system,
siphon is included with the appliance
- **HoodIn** – integrated steam condensation
- Built-in version
- Left hand hinged door
- Special voltage
- Interface for connection to an energy optimization system
according to DIN 18875 and potential free contact
- Potential free contact for external steam condensate hood
- ETHERNET interface
- Mains connection cable with 5-channel CEE plug 16 A
- Mains connection cable with earthed plug

Product safety



Combi steamer
Junior
 Electric combi steamer Junior MagicPilot 6.23
 MKN-No.: SKECOD623TG2



world of cooking

SKECOD623TG2

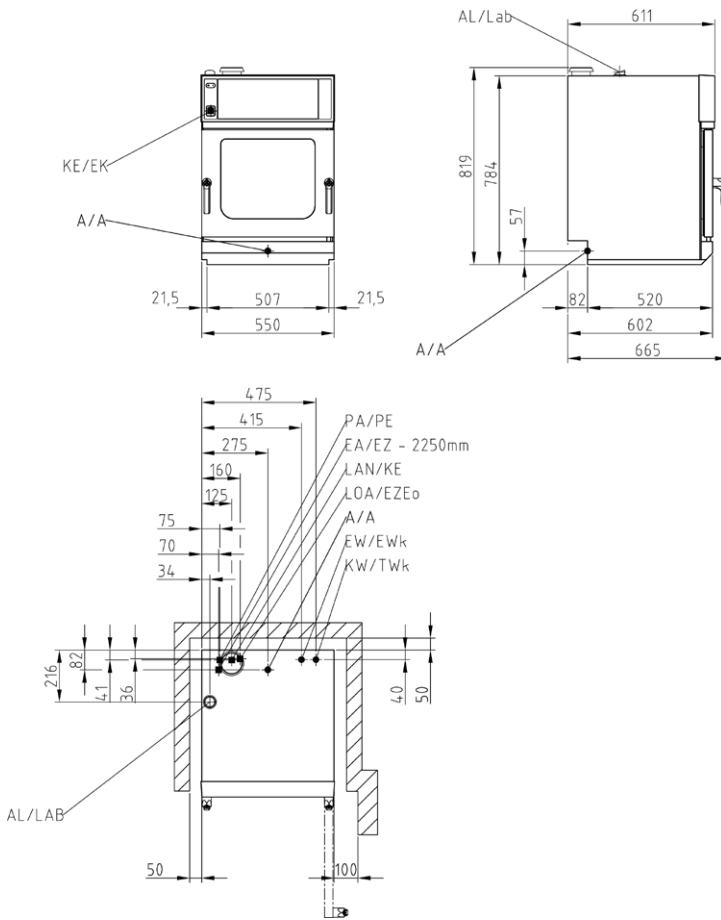

Please find detailed information at
www.mkn.com/en/login

General installation interfaces

Interfaces provided on site

- Electricity connection (EA/EZ)
- Connection to cold water mains (KW/TWk)
- Soft water (EW/EWk)
- Waste water connection (A/A)
- Exhaust air (AL)

Appliance dimensions (LxWxH) (mm)	550 x 611 x 784
Housing material	1.4301
Built-in dimensions (LxWxH) (mm)	550 x 612 x 800
Dimensions incl. packing (LxWxH ²)(mm)	800 x 800 x 1000
Net weight (kg)	68
Gross weight (kg)	82
Installation instructions; safety clearance in mm	
at the rear	50

Combi steamer

Junior

Electric combi steamer Junior MagicPilot 6.23

MKN-No.: SKECOD623TG2



world of cooking

SKECOD623TG2

Capacity	
Shelf inserts	6
GN 2/3 (354 x 325 x 60 mm)	6
Plates Ø 28 cm on regeneration racks	6
Meals per day	20 - 50

Electricity supply (400 V)	
Nominal power consumption (kW)	5.2
Voltage (V)	400 3 (N)PE AC
Fuse protection (A)	3 x 16
Frequency range (Hz)	50 / 60

Electricity supply (230 V)	
Nominal power consumption (kW)	3.5
Voltage (V)	230 1 NPE AC
Fuse protection (A)	1 x 16
Frequency range (Hz)	50 / 60

Drinking water cold (KW/TWK)	
Water pressure (bar)	2 - 6
Connection size	DN 20 (G ¾" A)
Quality mmol/l (°dH)	< 4 (22.2)
Consumption cleaning (l)	17.7

Soft water (EW/EWk)	
Water pressure (bar)	2 - 6
Connection size	DN 20 (G ¾" A)
Quality mmol/l (°dH)	< 0.9 (5)
Consumption steaming (l/h)	7.5
Consumption combisteaming (l/h)	1.7
Consumption cleaning (l)	1.3

Waste water (A/A)	
Volume flow max. (l/min.)	10
Connection size	DN 40
Quality	max. 95 °C

According to VDI 2052 with a connection voltage of 400 V.	
Operated without HoodIn (integrated steam condensation)	
Heat emission latent (W)	936
Heat emission sensitive (W)	624
Steam output (g/h)	1378
Operated with HoodIn (integrated steam condensation)	
Heat emission latent (W)	281
Heat emission sensitive (W)	624
Steam output (g/h)	413
Operated as built-in version with HoodIn	
Heat emission latent (W)	281
Heat emission sensitive (W)	624
Steam output (g/h)	413
Noise level (db (A))	< 65
Type of protection	IPX5

Combi steamer
Junior
 Electric combi steamer Junior MagicPilot 6.23
 MKN-No.: SKECOD623TG2



world of cooking

SKECOD623TG2

Further features

- One hand door handle
- Non-contact door switch, door lock positions with end stop
- Insertable door seal – end user replaceable
- Drip pan with permanent drainage
- **DynaSteam** – dynamic process-oriented steam quantity adjustment depending on product load
- Dynamic autoreverse fan for extremely uniform cooking results
- 5 fan speeds programmable, even 10 speeds in connection with fan intervals
- Fan safety brake
- Manual cleaning programme with user guide
- Maintenance instructions for external water filters
- **Time2Serve** – enter the required completion time
- **RackControl** – multiple timer
- **ClimaSelect plus** – Climate control in steps of 10 %
- **Ready2Cook** – preheating, cooling down, climate preparation
- **PerfectHold** – keep warm function with SmartCoolDown
- Internal multipoint core temperature measurement (up to 99 °C)
- **EcoModus** – reduces temperature of cooking chamber automatically when it has not been charged for some time
- Energy supply as required
- Integrated HACCP memory
- **Professional baking function** – to set baking programmes with humidity injection in ml, a rest period and dehumidification
- Manual steam injection/humidification
- Timer with start time pre-selection and real time display
- USB interface, e.g. for software updates**
- Cooking process import function using a USB stick
- Loudspeaker, adjustable tone control
- Audible signal after cooking time has elapsed
- Direct waste water connection according to DVGW is possible

Special equipment

10022549	Cabinet frame open on all sides, 850 mm high
10026739	Cabinet frame open on all sides, 100 mm high
SK_MAGICHOOD	MagicHood – odour neutralizing hood (see separate data sheet)
10026814	Junior stacking kit

GN 2/3 tray (please refer to accessories brochure)

10012900	Frying basket
202353	Granite enamelled tray, 20 mm deep
202359	Baking tray – perforated
206046	Grid
206028	Chicken grill rack
202356	Container, non-perforated, 20 mm deep
202358	Container, perforated, 40 mm deep
10022565	Wall bracket
10014181	Barcode scanner including USB cable for charging
TWO_IN_ONE	WaveClean two-in-one cleaning cartridge
10022638	Hanging racks 5 x GN 2/3, distance between insert levels 65 mm

** without surcharge under www.mkn.com

MKN Maschinenfabrik
 Kurt Neubauer GmbH & Co. KG
 Halberstaedter Strasse 2a
 38300 Wolfenbuettel / Germany

Phone +49 (0)5331 89-0
 Fax +49 (0)5331 89-280
 E-mail verkauf@mkn.de
www.mkn.com



Please find detailed information at www.mkn.com/en/login

Subject to technical modifications!
 Version: 25.11.2020